

**DISCHI PER ERPICE, PER FRANGIZOLLE E PER SEMINATRICE  
DISCS FOR HARROWS PLOUGHS AND SEEDERS  
SCHEIBE FÜR SCHOLLEN BRECHER, SÄEMASCHINE UND EGGE  
DISQUES POUR HERSES, BRISE-MOTTES ET SEMOIRS**





**DISCHI PER ERPICE, PER FRANGIZOLLE E PER SEMINATRICE**  
**DISCS FOR HARROWS PLOUGHS AND SEEDERS**  
**SCHEIBE FÜR SCHOLLEN BRECHER, SÄEMASCHINE UND EGGE**  
**DISQUES POUR HERSES, BRISE-MOTTES ET SEMOIRS**



Marca della macchina Machine brand name Marche des machines Marque de la machine	Quote Dimensions Abmessungen Dimensions mm	Codice Nr. Ref. Nr. Re. Nr. Ref. Nr.	Piatto Plate Platte Plaque mm	Fori Holes Löcher Trous Ø mm	Peso Weight Gewicht Poids gr
---	--	---	---	--	--

**DISCHI PER ERPICE  
BOMBATI E DENTATI**

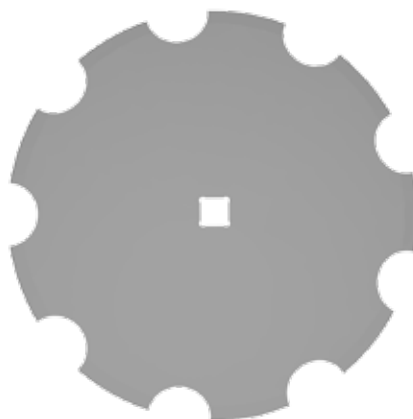

<b>Disco dentato 460 (18")</b>	A = 460 B = 51	disco 25/D	Spessore 3,25	∅ 26	4200
<b>Disco dentato 510 (20")</b>	A = 510 B = 59	disco 03/D	Spessore 4	∅ 26	5900
<b>Disco dentato 510 (20")</b>	A = 510 B = 59	disco 04/D	Spessore 4	∅ 31	5900
<b>Disco dentato 510 (20")</b>	A = 510 B = 56	disco 21/D	Spessore 4	∅ 36	5900
<b>Disco dentato 510 (20")</b>	A = 510 B = 59	disco 29/D	Spessore 4	∅ 67	5900
<b>Disco dentato 510 (20")</b>	A = 510 B = 59	disco 38/D	Spessore 3,25	∅ 31	4700
<b>Disco dentato 560 (22")</b>	A = 560 B = 71	disco 07/D	Spessore 4,5	∅ 26	7600
<b>Disco dentato 560 (22")</b>	A = 560 B = 71	disco 08/D	Spessore 4,5	∅ 31	7600

Tutti i modelli sono di nostra produzione e non originali.  
 All models are of our manufacture and are not original.  
 Alle unsere Landwirtschaftliche erzeugnisse sind unsere produktion und sind nicht original.  
 Tous les modèles sont notre production et ne sont pas des produits d'origine.

N.B. Pesi e misure sopra descritti sono puramente indicativi.  
 N.B. The above weights and dimensions are given for reference only.  
 N.B. Die obengenannten Gewichte und Abmessungen sind richtungsweisend.  
 N.B. Les poids et les dimensions indiqués ci-dessus sont donnés à titre indicatif.

© La riproduzione  
 anche parziale  
 del presente catalogo  
 è vietata.

**DISCHI PER ERPICE, PER FRANGIZOLLE E PER SEMINATRICI**  
**DISCS FOR HARROWS PLOUGHS AND SEEDERS**  
**SCHEIBE FÜR SCHOLLEN BRECHER, SÄEMASCHINE UND EGGE**  
**DISQUES POUR HERSES, BRISE-MOTTES ET SEMOIRS**



Marca della macchina Machine brand name Marche des machines Marque de la machine	Quote Dimensions Abmessungen Dimensions mm	Codice Nr. Ref. Nr. Re. Nr. Ref. Nr.	Piatto Plate Platte Plaque mm	Fori Holes Löcher Trous Ø mm	Peso Weight Gewicht Poids gr
<b>Disco dentato 560 (22")</b>	A = 560 B = 68	disco 19/D	Spessore 4,5	∅ 36	7600
<b>Disco dentato 560 (22")</b>	A = 560 B = 71	disco 23/D	Spessore 4,5	∅ 67	7600
<b>Disco dentato 610 (24")</b>	A = 610 B = 86	disco 11/D	Spessore 5	∅ 31	10800
<b>Disco dentato 610 (24")</b>	A = 610 B = 86	disco 12/D	Spessore 5	∅ 41	10800
<b>Disco dentato 610 (24")</b>	A = 610 B = 86	disco 27/D	Spessore 5	∅ 67	10800
<b>Disco dentato 660 (26")</b>	A = 660 B = 97	disco 50/D	Spessore 6	∅ 41	16500
<b>Disco dentato 710 (28")</b>	A = 710 B = 102	disco 31/D	Spessore 6	∅ 41	18300

**DISCHI PER ERPICE, PER FRANGIZOLLE E PER SEMINATRICE**  
**DISCS FOR HARROWS PLOUGHS AND SEEDERS**  
**SCHEIBE FÜR SCHOLLEN BRECHER, SÄEMASCHINE UND EGGE**  
**DISQUES POUR HERSES, BRISE-MOTTES ET SEMOIRS**



Marca della macchina Machine brand name Marche des machine Marque de la machine	Quote Dimensions Abmessungen Dimensions mm	Codice Nr. Ref. Nr. Re. Nr. Ref. Nr.	Piatto Plate Platte Plaque mm	Fori Holes Löcher Trous Ø mm	Peso Weight Gewicht Poids gr
--	--	---	---	--	--

**DISCHI PER ERPICE  
BOMBATI LISCI**

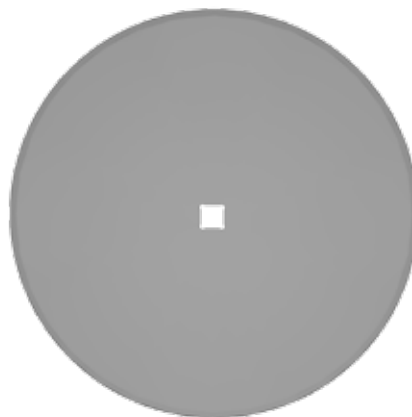

<b>Disco liscio 460 (18")</b>	A = 460 B = 51	disco 13/L	Spessore 3,25	∅ 26	4200
<b>Disco liscio 460 (18")</b>	A = 460 B = 51	disco 14/L	Spessore 3,25	∅ 31	4200
<b>Disco liscio 510 (20")</b>	A = 510 B = 59	disco 01/L	Spessore 4	∅ 26	6500
<b>Disco liscio 510 (20")</b>	A = 510 B = 59	disco 02/L	Spessore 4	∅ 31	6500
<b>Disco liscio 510 (20")</b>	A = 510 B = 56	disco 22/L	Spessore 4	∅ 36	6500
<b>Disco liscio 510 (20")</b>	A = 510 B = 59	disco 28/L	Spessore 4	∅ 67	6500
<b>Disco liscio 510 (20")</b>	A = 510 B = 59	disco 35/L	Spessore 3,25	∅ 26	5100
<b>Disco liscio 510 (20")</b>	A = 510 B = 59	disco 36/L	Spessore 3,25	∅ 31	5900

Tutti i modelli sono di nostra produzione e non originali.  
 All models are of our manufacture and are not original.  
 Alle unsere Landwirtschaftliche erzeugnisse sind unsere produktion und sind nicht original.  
 Tous les modèles sont notre production et ne sont pas des produits d'origine.

N.B. Pesi e misure sopra descritti sono puramente indicativi.  
 N.B. The above weights and dimensions are given for reference only.  
 N.B. Die obengenannten Gewichte und Abmessungen sind richtungsweisend.  
 N.B. Les poids et les dimensions indiqués ci-dessus sont donnés à titre indicatif.

© La riproduzione  
 anche parziale  
 del presente catalogo  
 è vietata.

**DISCHI PER ERPICE, PER FRANGIZOLLE E PER SEMINATRICE**  
**DISCS FOR HARROWS PLOUGHS AND SEEDERS**  
**SCHEIBE FÜR SCHOLLEN BRECHER, SÄEMASCHINE UND EGGE**  
**DISQUES POUR HERSES, BRISE-MOTTES ET SEMOIRS**



Marca della macchina Machine brand name Marche des machine Marque de la machine	Quote Dimensions Abmessungen Dimensions mm	Codice Nr. Ref. Nr. Re. Nr. Ref. Nr.	Piatto Plate Platte Plaque mm	Fori Holes Löcher Trous Ø mm	Peso Weight Gewicht Poids gr
<b>Disco liscio 560 (22")</b>	A = 560 B = 71	disco 05/L	Spessore 4,5	∅ 26	8600
<b>Disco liscio 560 (22")</b>	A = 560 B = 71	disco 06/L	Spessore 4,5	∅ 31	8600
<b>Disco liscio 560 (22")</b>	A = 560 B = 68	disco 20/L	Spessore 4,5	∅ 36	8600
<b>Disco liscio 560 (22")</b>	A = 560 B = 71	disco 24/L	Spessore 4,5	∅ 67	7600
<b>Disco liscio 610 (24")</b>	A = 610 B = 86	disco 09/L	Spessore 5	∅ 31	12000
<b>Disco liscio 610 (24")</b>	A = 610 B = 86	disco 10/L	Spessore 5	∅ 41	12000
<b>Disco liscio 610 (24")</b>	A = 610 B = 86	disco 26/L	Spessore 5	∅ 67	12000
<b>Disco liscio 660 (26")</b>	A = 660 B = 97	disco 33/L	Spessore 6	∅ 5 fori	17500
<b>Disco liscio 660 (26")</b>	A = 660 B = 97	disco 51/L	Spessore 6	∅ 41	17500
<b>Disco liscio 710 (28")</b>	A = 710 B = 102	disco 32/L	Spessore 6	∅ 41	21000

**DISCHI PER ERPICE, PER FRANGIZOLLE E PER SEMINATRICI**  
**DISCS FOR HARROWS PLOUGHS AND SEEDERS**  
**SCHEIBE FÜR SCHOLLEN BRECHER, SÄEMASCHINE UND EGGE**  
**DISQUES POUR HERSES, BRISE-MOTTES ET SEMOIRS**



Marca della macchina Machine brand name Marche des machine Marque de la machine	Tipo Type Type Type	Codice Nr. Ref. Nr. Re. Nr. Ref. Nr.	Marca della macchina Machine brand name Marche des machine Marque de la machine	Tipo Type Type Type	Peso Weight Gewicht Poids gr
--	------------------------------	---	--	------------------------------	--

**DISCHI PER ERPICE E SEMINATRICI**

<b>Lemken/Rubin</b> <b>Disco dentato 625x6</b> <b>3490467</b>	<b>A = 625</b> <b>B = 60</b>	<b>Disco 108/D</b>	<b>Spessore 6</b>	 <b>5 fori 12,5</b>	<b>12600</b>
---	---------------------------------	--------------------	-------------------	------------------------	--------------

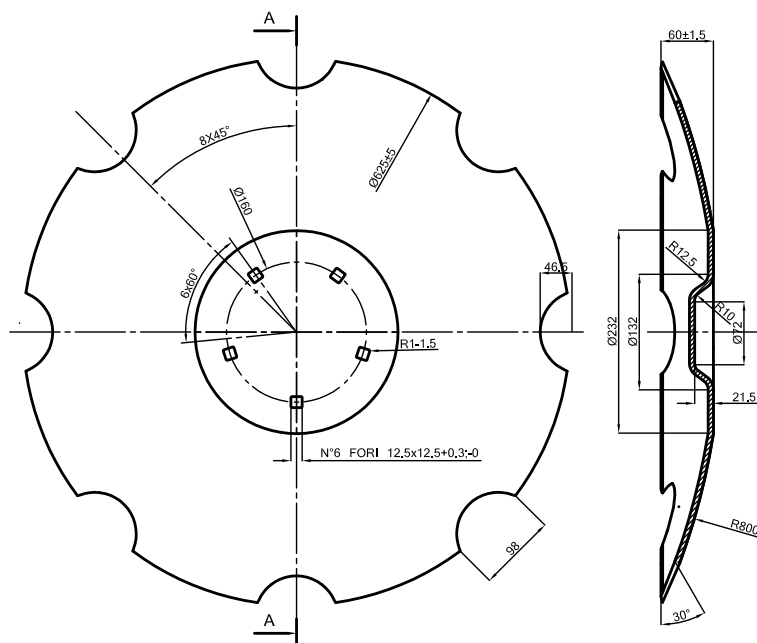
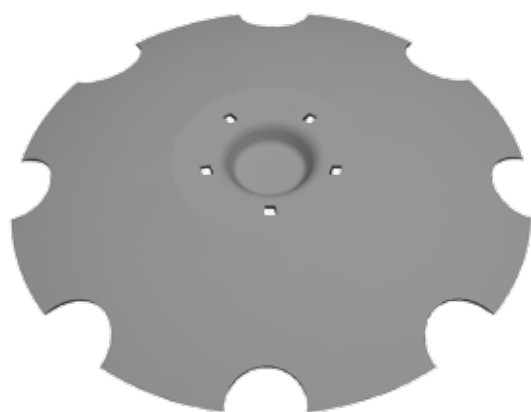

<b>Lemken/Rubin</b> <b>Disco dentato 625x6</b> <b>3490466</b>	<b>A = 625</b> <b>B = 65</b>	<b>Disco 109/D</b>	<b>Spessore 6</b>	 <b>6 fori 12,5</b>	<b>13200</b>
---	---------------------------------	--------------------	-------------------	------------------------	--------------

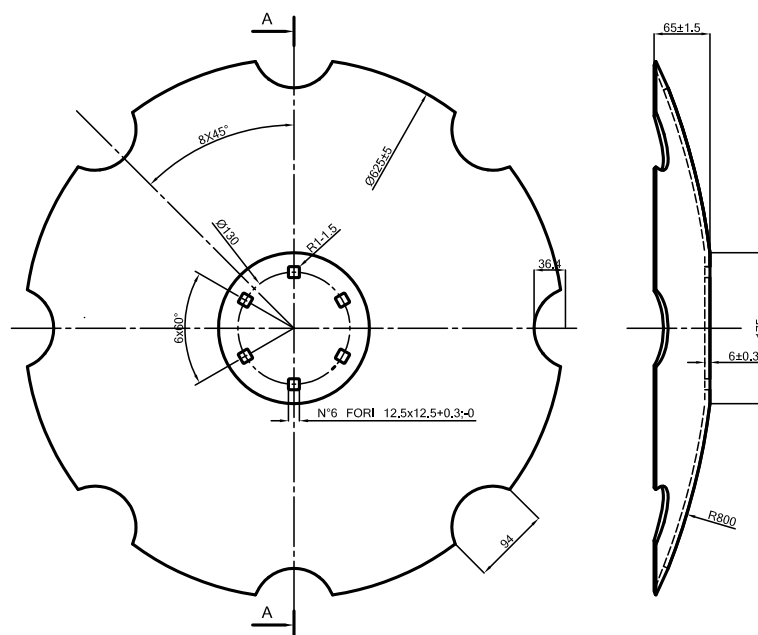
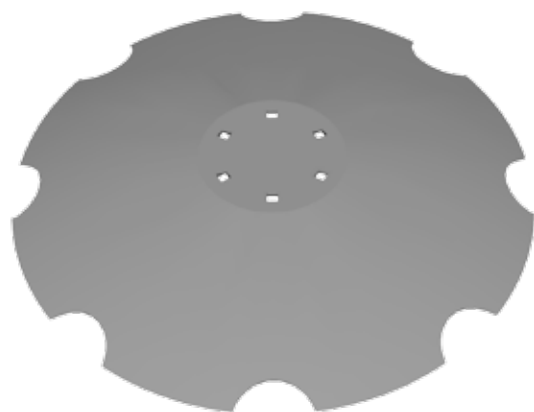

Tutti i modelli sono di nostra produzione e non originali.  
 All models are of our manufacture and are not original.  
 Alle unsere Landwirtschaftliche erzeugnisse sind unsere produktion und sind nicht original.  
 Tous les modèles sont notre production et ne sont pas des produits d'origine.

N.B. Pesi e misure sopra descritti sono puramente indicativi.  
 N.B. The above weights and dimensions are given for reference only.  
 N.B. Die obengenannten Gewichte und Abmessungen sind richtungweisend.  
 N.B. Les poids et les dimensions indiqués ci-dessus sont donnés à titre indicatif.

© La riproduzione anche parziale del presente catalogo è vietata.

**DISCHI PER ERPICE, PER FRANGIZOLLE E PER SEMINATRICE**  
**DISCS FOR HARROWS PLOUGHS AND SEEDERS**  
**SCHEIBE FÜR SCHOLLEN BRECHER, SÄEMASCHINE UND EGGE**  
**DISQUES POUR HERSES, BRISE-MOTTES ET SEMOIRS**



Marca della macchina Machine brand name Marche des machine Marque de la machine	Tipo Type Type Type	Codice Nr. Ref. Nr. Re. Nr. Ref. Nr.	Marca della macchina Machine brand name Marche des machine Marque de la machine	Tipo Type Type Type	Peso Weight Gewicht Poids gr
--	------------------------------	---	--	------------------------------	--

<b>Horsch</b> <b>Disco dentato 460x4</b> <b>23246102</b>	A = 460 B = 50	Disco 118/D	Spessore 4	∅ 3 fori 13	4470
--	-------------------	-------------	------------	----------------	------

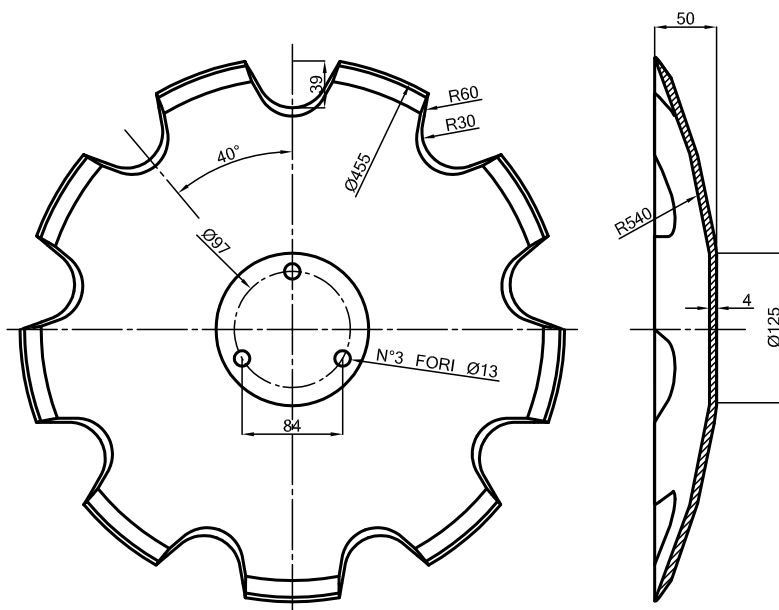
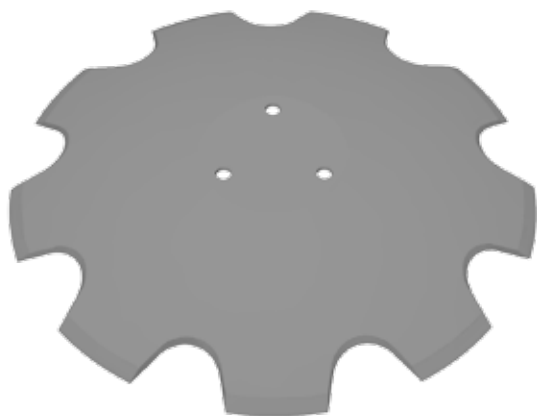

<b>Horsch</b> <b>Disco dentato 460x6</b> <b>23246103</b>	A = 460 B = 52	Disco 119/D	Spessore 6	∅ 3 fori 13	6670
--	-------------------	-------------	------------	----------------	------

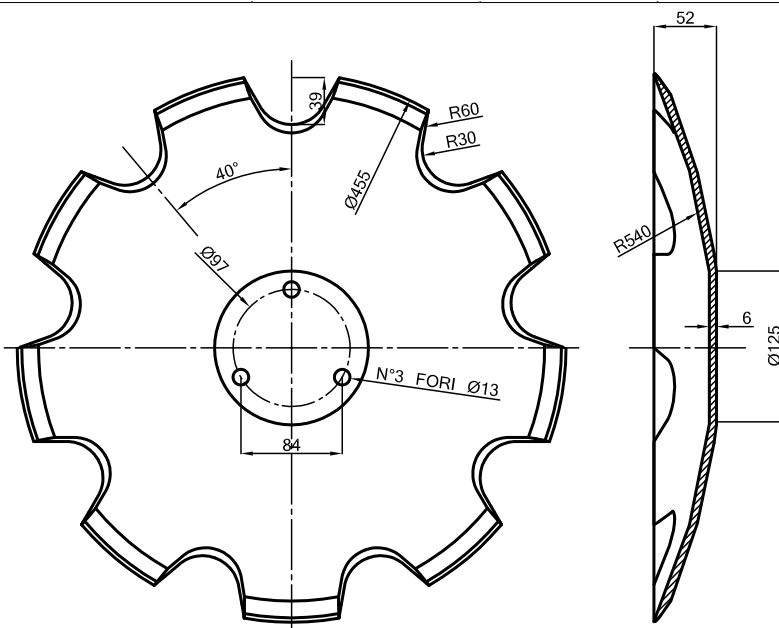



**DISCHI PER ERPICE, PER FRANGIZOLLE E PER SEMINATRICE**  
**DISCS FOR HARROWS PLOUGHS AND SEEDERS**  
**SCHEIBE FÜR SCHOLLEN BRECHER, SÄEMASCHINE UND EGGE**  
**DISQUES POUR HERSES, BRISE-MOTTES ET SEMOIRS**



Marca della macchina Machine brand name Marche des machine Marque de la machine	Tipo Type Type Type	Codice Nr. Ref. Nr. Re. Nr. Ref. Nr.	Marca della macchina Machine brand name Marche des machine Marque de la machine	Tipo Type Type Type	Peso Weight Gewicht Poids gr
--	------------------------------	---	--	------------------------------	--

<b>Amazone</b> <b>Disco liscio 325x3</b> <b>962292</b>	A = 325 B = 22	Disco 120/L	Spessore 3	∅ 3 fori 10,5x19	1865
--	-------------------	-------------	------------	------------------------	------

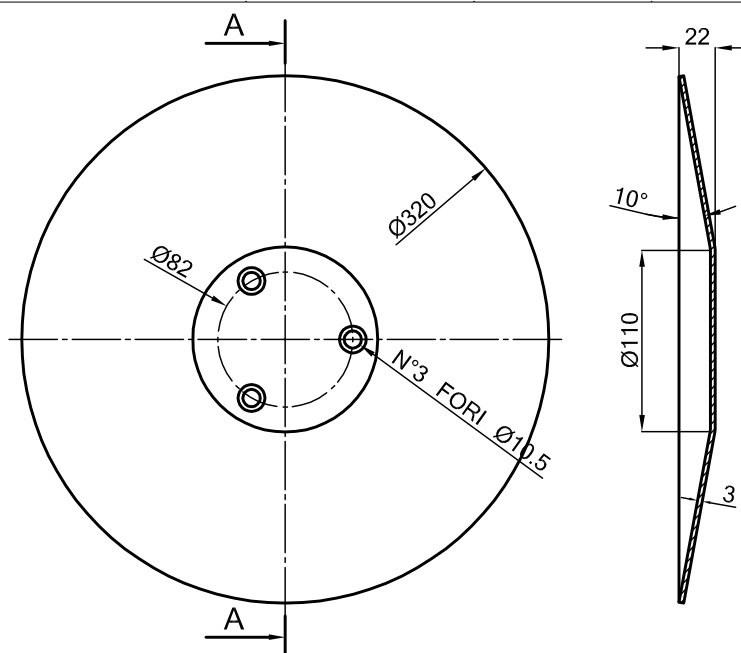
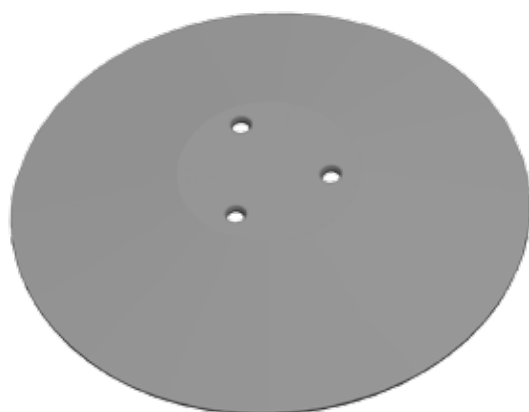

<b>Amazone</b> <b>Disco liscio 460x4</b> <b>XL011</b>	A = 460 B = 44	Disco 121/L	Spessore 4	∅ 4 fori 12,5	5300
---	-------------------	-------------	------------	------------------	------

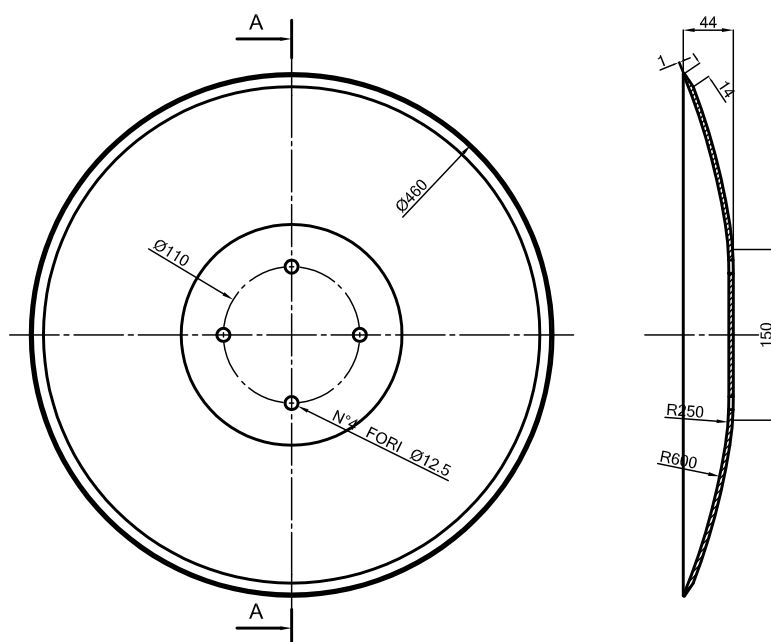
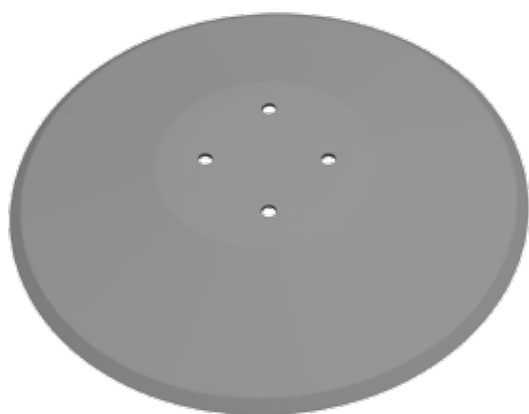

Tutti i modelli sono di nostra produzione e non originali.  
 All models are of our manufacture and are not original.  
 Alle unsere Landwirtschaftliche erzeugnisse sind unsere produktion und sind nicht original.  
 Tous les modèles sont notre production et ne sont pas des produits d'origine.

N.B. Pesi e misure sopra descritti sono puramente indicativi.  
 N.B. The above weights and dimensions are given for reference only.  
 N.B. Die obengenannten Gewichte und Abmessungen sind richtungweisend.  
 N.B. Les poids et les dimensions indiqués ci-dessus sont donnés à titre indicatif.

© La riproduzione  
 anche parziale  
 del presente catalogo  
 è vietata.

**DISCHI PER ERPICE, PER FRANGIZOLLE E PER SEMINATRICE**  
**DISCS FOR HARROWS PLOUGHS AND SEEDERS**  
**SCHEIBE FÜR SCHOLLEN BRECHER, SÄEMASCHINE UND EGGE**  
**DISQUES POUR HERSES, BRISE-MOTTES ET SEMOIRS**



Marca della macchina Machine brand name Marche des machine Marque de la machine	Tipo Type Type Type	Codice Nr. Ref. Nr. Re. Nr. Ref. Nr.	Marca della macchina Machine brand name Marche des machine Marque de la machine	Tipo Type Type Type	Peso Weight Gewicht Poids gr
--	------------------------------	---	--	------------------------------	--

<b>Amazone</b> <b>Disco liscio 460x4</b> <b>XL041</b>	A = 460 B = 42	Disco 122/L	Spessore 4	$\varnothing$ 4 fori 11,5	5060
---	-------------------	-------------	------------	------------------------------	------

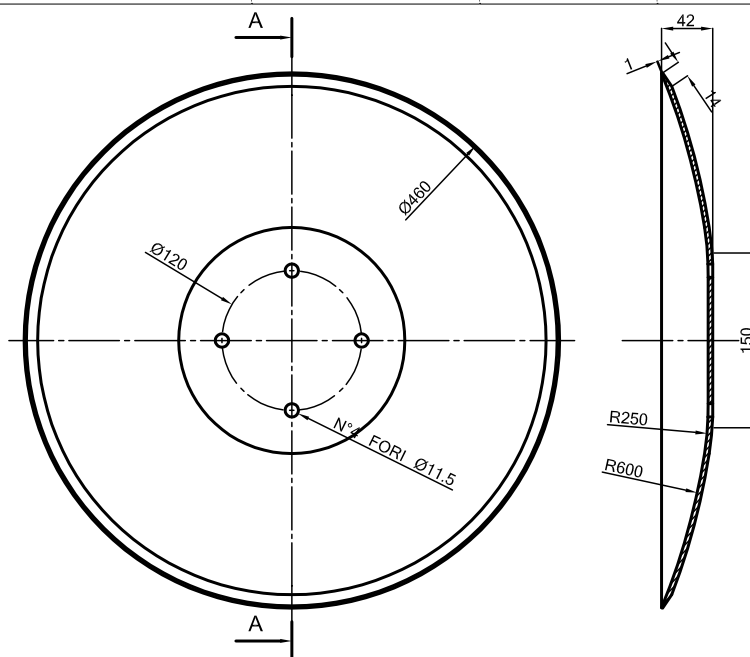
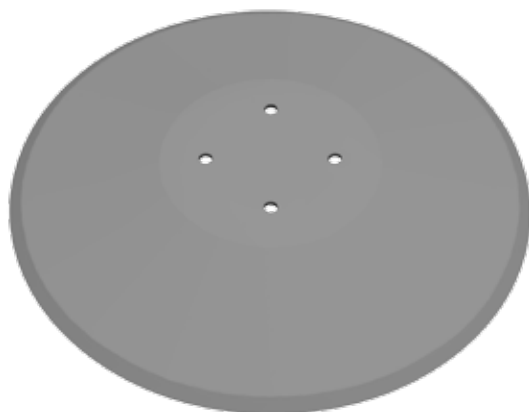

<b>Vaderstad</b> <b>Disco dentato 405x4,5</b> <b>451372-423574-444568</b>	A = 405 B = 16	Disco 123/D	Spessore 4,5	$\varnothing$ 5 fori 13	4360
---	-------------------	-------------	--------------	----------------------------	------

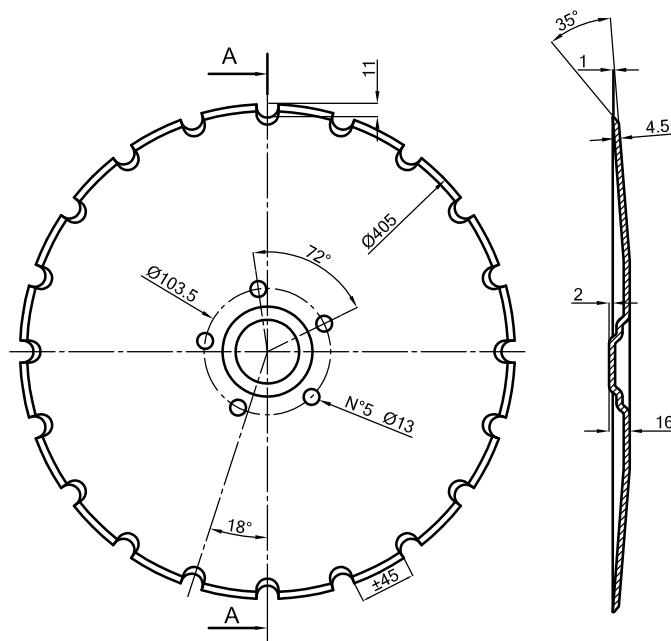
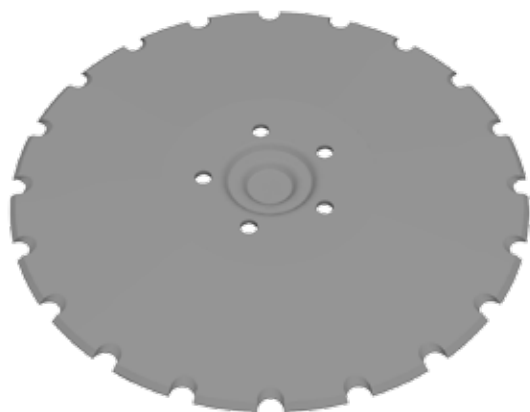

**DISCHI PER ERPICE, PER FRANGIZOLLE E PER SEMINATRICI**  
**DISCS FOR HARROWS PLOUGHS AND SEEDERS**  
**SCHEIBE FÜR SCHOLLEN BRECHER, SÄEMASCHINE UND EGGE**  
**DISQUES POUR HERSES, BRISE-MOTTES ET SEMOIRS**



Marca della macchina Machine brand name Marche des machines Marque de la machine	Tipo Type Type Type	Codice Nr. Ref. Nr. Re. Nr. Ref. Nr.	Marca della macchina Machine brand name Marche des machines Marque de la machine	Tipo Type Type Type	Peso Weight Gewicht Poids gr
---	------------------------------	---	---	------------------------------	--

<b>Vaderstad</b> <b>Disco dentato 430x4,5</b> <b>459114-444687-459608</b>	A = 430 B = 26	Disco 124/D	Spessore 4,5	∅ 4 fori 20x13	5540
---	-------------------	-------------	--------------	-------------------	------

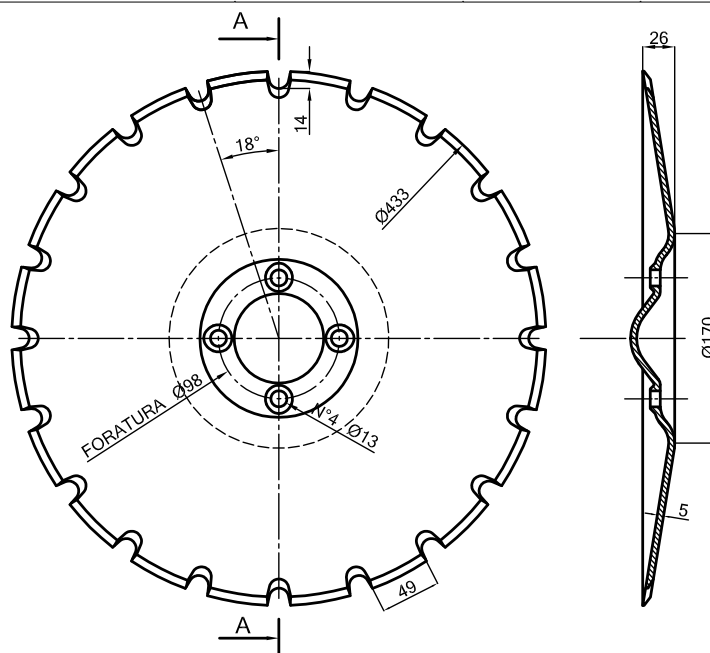

<b>Vaderstad</b> <b>Disco dentato 410x5 (16")</b> <b>451371</b>	A = 410	Disco 125/D	Spessore 5	∅ 5 fori 13	4476
---	---------	-------------	------------	----------------	------

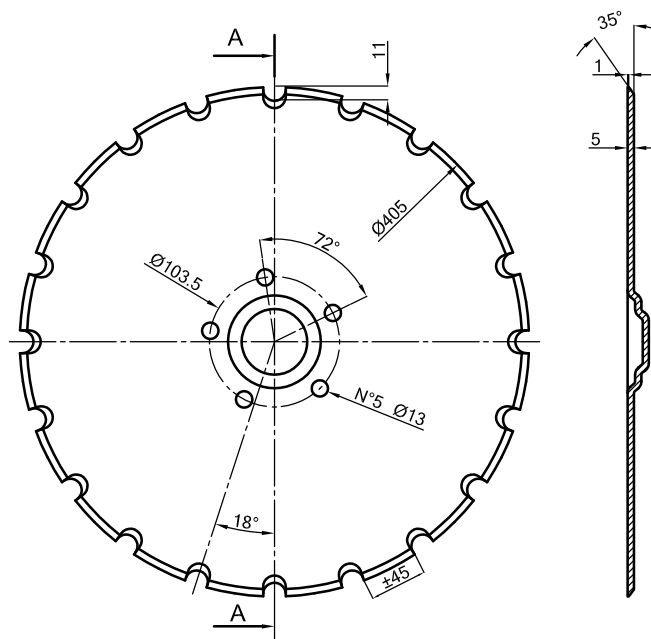

Tutti i modelli sono di nostra produzione e non originali.  
 All models are of our manufacture and are not original.  
 Alle unsere Landwirtschaftliche erzeugnisse sind unsere produktion und sind nicht original.  
 Tous les modèles sont notre production et ne sont pas des produits d'origine.

N.B. Pesi e misure sopra descritti sono puramente indicativi.  
 N.B. The above weights and dimensions are given for reference only.  
 N.B. Die obengenannten Gewichte und Abmessungen sind richtungweisend.  
 N.B. Les poids et les dimensions indiqués ci-dessus sont donnés à titre indicatif.

© La riproduzione anche parziale del presente catalogo è vietata.

